

TADANO ROUGH TERRAIN CRANE

MODEL : GR-120NL

(Right-hand steering)

GENERAL DATA

<u>CRANE CAPACITY</u>	12,000 kg at 2.0 m
<u>BOOM</u>	6-section, 5.3 m - 23.8 m
<u>DIMENSIONS</u>	
Overall length	approx. 7,540 mm
Overall width	approx. 2,000 mm
Overall height	approx. 2,815 mm
<u>MASS</u>	
Gross vehicle mass	approx. 14,145 kg
front axle	approx. 7,100 kg
rear axle	approx. 7,045 kg
<u>PERFORMANCE</u>	
Max. travelling speed	computed 49 km/h
Gradeability (tan θ)	computed 53 %

Specifications are subject to change without notice.

CRANE SPECIFICATIONS

<u>MODEL</u>	GR-120NL
<u>CAPACITY</u>	12,000 kg at 2.0 m
<u>BOOM</u>	<p>Six-section full length power telescoping boom of box construction with 4 sheaves at boom head. 4th, 5th and top boom section, as well as 2nd and 3rd boom section, telescope synchronously by means of a double-acting cylinder, extension cables and retraction cables.</p> <p>Hydraulic cylinders fitted with holding valves.</p> <p>Fully retracted length..... 5.3 m</p> <p>Fully extended length.....23.8 m</p> <p>Extension speed.....18.5 m in 52 s</p>
<u>JIB</u>	<p>Two-staged extension type. Quadruple offset ($5^{\circ}/25^{\circ}/45^{\circ}/60^{\circ}$) type. Single sheave at jib head.</p> <p>Stored under base boom section.</p> <p>Length.....3.6 m and 5.5 m</p>
<u>SINGLE TOP (AUXILIARY BOOM SHEAVE)</u>	Single sheave. Mounted to main boom head for single line work.
<u>ELEVATION</u>	<p>By a double-acting hydraulic cylinder, fitted with holding valve.</p> <p>Elevation speed.....-3° to 82° in 29 s</p>
<u>HOIST -Main winch</u>	<p>Grooved drum driven by hydraulic axial piston motor through winch speed reducer. Power load lowering and hoisting.</p> <p>Equipped with automatic brake (neutral brake) and counterbalance valve.</p> <p>Controlled independently of auxiliary winch.</p> <p>Single line pull.....17.7 kN {1,800 kgf}</p> <p>Single line speed.....125 m/min. (at the 5th layer)</p> <p>Wire rope.....Spin-resistant type</p> <p>Diameter x length.....11.2 mm x 132 m</p>
<u>HOOK BLOCK- 12 t capacity</u>	4 sheaves, swivel type hook with safety latch.

<u>HOIST - Auxiliary winch</u>	<p>Grooved drum driven by hydraulic axial piston motor through winch speed reducer. Power load lowering and hoisting.</p> <p>Equipped with automatic brake (neutral brake) and counterbalance valve.</p> <p>Controlled independently of main winch.</p> <p style="padding-left: 40px;">Single line pull.....17.7 kN {1,800 kgf}</p> <p style="padding-left: 40px;">Single line speed.....110 m/min. (at the 3rd layer)</p> <p style="padding-left: 40px;">Wire rope.....Spin-resistant type</p> <p style="padding-left: 80px;">Diameter x length.....11.2 mm x 66 m</p>
<u>HOOK BLOCK- 1.8 t capacity</u>	<p>Swivel hook with safety latch for single line use.</p>
<u>SWING</u>	<p>A hydraulic piston motor driven through planetary swing speed reducer. Continuous 360° full circle swing on ball bearing slew ring. Equipped with spring loaded swing brake.</p> <p style="padding-left: 40px;">Swing speed.....2.4 min⁻¹{rpm}</p>
<u>HYDRAULIC SYSTEM</u>	<p>Pumps.....Two variable piston pumps for telescoping, elevating and winches. Tandem gear pump for swing, steering and accumulator.</p> <p>Control valves...Multiple valves actuated by pilot pressure with integral pressure relief valves.</p> <p>Circuit.....Equipped with air cooled type oil cooler. Oil pressure appears on AML display for main circuit.</p> <p>Hydraulic oil tank capacity....</p> <p style="padding-left: 40px;">approx. 172 liters</p> <p>Filters.....Return line filter</p>
<u>CAB</u>	<p>Both crane and drive operations can be performed from cab mounted on rotating superstructure. One sided one-man type, steel construction cab with safety glass, sliding door access and windows opening at side and rear. 3-way adjustable, shoulder- supportable, cloth-covered operator's suspension seat with armrest.</p>

TADANO Automatic
Moment Limiter
(Model:AML-C)

Main unit in crane cab gives audible and visual warning of approach to overload. Automatically cuts out crane motions (including swing motion) before overload. With working range (load radius and/or boom angle and/or tip height and/or swing range) limit function.

Following functions are displayed.

- Moment as percentage
- Number of parts of line of rope
- Boom angle
- Boom length
- Load radius
- Outriggers position or on-tire indicator
- Actual hook load
- Permissible load
- Boom position indicator
- Potential hook height
- Swing angle
- Main hydraulic oil pressure
- Jib length and jib offset angle (only when jib operation)

OUTRIGGERS

Hydraulically operated H-type outriggers. Each outrigger controlled simultaneously or independently from the cab.

Equipped with sight level gauge. Floats mounted integrally with the jacks retract to within vehicle width.

All jack cylinders fitted with pilot check valves.

Equipped with extension width detector for each outrigger.

Extended width

Fully.....4,700 mm

Middle.....4,300 mm, 3,500 mm, 2,500 mm

Minimum.....1,640 mm

Float size (Diameter)...350 mm

NOTE : Each crane motion speed is based on unladen conditions.

CARRIER SPECIFICATIONS

<u>TYPE</u>	Rear engine, right-hand steering, driving axle 2-way selected type (by manual switch). 4 x 2 front drive 4 x 4 front and rear drive
<u>FRAME</u>	High-tensile steel, all welded box construction.
<u>ENGINE</u>	Model.....MITSUBISHI 4M50-TLU3B Type.....4 cycle, turbo charged and after cooled, 4 cylinder in line, direct injection, water cooled diesel engine. Piston displacement....4,899 cm ³ Bore x stroke.....114 mm x 120 mm Max. output129 kW {175 PS} at 2,700 min ⁻¹ {rpm} Max. torque530 N-m {54.0 kgf-m} at 1,600 min ⁻¹ {rpm}
<u>TRANSMISSION</u>	Full automatic transmission. Torque converter (with automatic lock up device at forward 1st, 2nd and 3rd of High range) driving full powershift. High range.....3 forward and 1 reverse speeds. Low range.....3 forward and 1 reverse speeds.
<u>AXLES</u>	Front.....Full floating type, steering and driving axle. Conventional differential. Rear.....Full floating type, steering and driving axle. Conventional differential.
<u>STEERING</u>	Hydraulic power steering controlled by steering wheel. 4 steering modes available: 2-wheel front 2-wheel rear 4-wheel coordinated 4-wheel crab
<u>SUSPENSION</u>	Front.....Semi-elliptic leaf springs with hydraulic lockout device. Rear.....Semi-elliptic leaf springs with hydraulic lockout device.
<u>BRAKE SYSTEM</u>	Service.....Air over hydraulic disc brakes on all 4 wheels. Parking.....Spring operated air released brake acting on input shaft of front axle. Auxiliary....Exhaust brake.
<u>ELECTRIC SYSTEM</u>	24 V DC. 2 batteries of 12 V
<u>FUEL TANK CAPACITY</u>	189 liters
<u>TIRES</u>	Front.....275/80R22.5, Single x 2 Rear.....275/80R22.5, Single x 2
<u>TURN RADIUS</u>	Min. turning radius(at center of extreme outer tire)..... 2-wheel steering.....6.5 m 4-wheel steering.....3.8 m

EQUIPMENT**STANDARD EQUIPMENT**

Automatic moment limiter (AML-C)
 Pendant type over-winding cutout
 Winch drum rotation indicator (Visual)
 Hook stowing device (Mechanically stowed beneath boom top portion)
 Hook safety latch
 Pilot check valves
 Holding valves
 Counterbalance valves
 Hydraulic pressure relief valves
 Swing brake
 Working area control device
 Swing signal lamp
 Boom elevation slowing-down and stop function
 Boom telescoping foot pedal
 Auxiliary winch foot pedal
 Outrigger extension width detector
 Sight level gauge
 Hydraulic oil cooler
 Electric windshield wiper and washer
 Roof window wiper and washer
 Tachometer/Speedometer
 Seat belt (Driver's seat)
 Air conditioner (Hot water heater type with dehumidification function)
 Power window (Right-hand door of the cab)
 Cab floor mat
 Sun visor (Roof and side)
 Neutral position adjustable crane control levers
 Automatic drive system
 Transmission neutral position engine start
 Overshift prevention
 Parking braked travel warning
 Rear steering lock
 Tilt-telescope steering wheel
 Back-up alarm
 Air cleaner dust indicator
 Air dryer
 Engine over-run alarm
 Hydraulic lockout suspension
 Towing eyes - front and rear
 Left front view monitor
 Emergency steering

OPTIONAL EQUIPMENT

External lamp (AML-C)
 Power stowing mirror
 Centralized lubricating system(Carrier portion)
 Tire inflation kit

RATED LIFTING CAPACITIES

ISO 4305

ON OUTRIGGERS

Unit : x1,000kg

Outriggers fully extended (4.7 m) - 360° rotation -						
A \ B	5.3 m	9.0 m	12.7 m	16.4 m	20.1 m	23.8 m
1.0 m	12.0	6.0				
1.5 m	12.0	6.0	6.0			
2.0 m	12.0	6.0	6.0	5.0		
2.5 m	10.0	6.0	6.0	5.0	4.7	
3.0 m	8.2	6.0	6.0	5.0	4.7	
3.5 m	7.0	6.0	6.0	5.0	4.7	3.2
4.0 m	6.1	6.0	5.35	4.85	4.25	3.2
4.5 m		5.35	4.75	4.35	3.85	3.2
5.0 m		4.7	4.25	3.9	3.55	3.0
5.5 m		4.15	3.8	3.55	3.3	2.9
6.0 m		3.75	3.45	3.2	3.05	2.75
7.0 m		3.05	2.85	2.7	2.55	2.35
8.0 m		2.7	2.4	2.3	2.2	2.1
9.0 m		(7.7m)	2.0	1.95	1.9	1.8
10.0 m			1.6	1.7	1.65	1.6
11.0 m			1.25	1.5	1.45	1.4
12.0 m			1.15	1.25	1.3	1.2
13.0 m			(11.4m)	1.05	1.15	1.1
14.0 m				0.9	0.95	1.0
15.0 m				0.75	0.85	0.9
16.0 m					0.7	0.8
17.0 m					0.6	0.65
18.0 m					0.5	0.55
19.0 m					0.4	0.45
20.0 m					(18.7m)	0.4
22.0 m						0.25
22.3 m						0.23
D (°)	0					

A : Boom length

B : Load radius

D : Minimum boom angle (°) for indicated length (no load)

RATED LIFTING CAPACITIES

ISO 4305

ON OUTRIGGERS

Unit : x1,000kg

Outriggers extended to middle (4.3 m) - Over side -						
A \ B	5.3 m	9.0 m	12.7 m	16.4 m	20.1 m	23.8 m
1.0 m	12.0	6.0				
1.5 m	12.0	6.0	6.0			
2.0 m	12.0	6.0	6.0	5.0		
2.5 m	10.0	6.0	6.0	5.0	4.7	
3.0 m	8.2	6.0	6.0	5.0	4.7	
3.5 m	7.0	6.0	6.0	5.0	4.7	3.2
4.0 m	6.1	6.0	5.35	4.85	4.25	3.2
4.5 m		5.35	4.75	4.35	3.85	3.2
5.0 m		4.7	4.25	3.9	3.55	3.0
5.5 m		4.15	3.8	3.55	3.3	2.9
6.0 m		3.75	3.45	3.2	3.05	2.75
7.0 m		3.05	2.85	2.7	2.55	2.35
8.0 m		2.6	2.35	2.3	2.2	2.1
9.0 m		(7.7m)	1.8	1.95	1.9	1.8
10.0 m			1.4	1.65	1.65	1.6
11.0 m			1.1	1.3	1.45	1.4
12.0 m			1.0	1.0	1.15	1.2
13.0 m			(11.4m)	0.8	0.95	1.1
14.0 m				0.65	0.75	0.9
15.0 m				0.5	0.6	0.75
16.0 m					0.5	0.65
17.0 m					0.4	0.5
18.0 m					0.3	0.43
19.0 m					0.25	0.35
20.0 m					(18.7m)	0.25
D (°)	0					

A : Boom length

B : Load radius

D : Minimum boom angle (°) for indicated length (no load)

RATED LIFTING CAPACITIES

ISO 4305

ON OUTRIGGERS

Unit : x1,000kg

Outriggers extended to middle (3.5 m) - Over side -						
A \ B	5.3 m	9.0 m	12.7 m	16.4 m	20.1 m	23.8 m
1.0 m	12.0	6.0				
1.5 m	12.0	6.0	6.0			
2.0 m	12.0	6.0	6.0	5.0		
2.5 m	10.0	6.0	6.0	5.0	4.7	
3.0 m	8.2	6.0	6.0	5.0	4.7	
3.5 m	7.0	6.0	6.0	5.0	4.7	3.2
4.0 m	6.1	6.0	5.35	4.85	4.25	3.2
4.5 m		5.0	4.75	4.35	3.85	3.2
5.0 m		4.05	4.05	3.9	3.55	3.0
5.5 m		3.35	3.3	3.55	3.3	2.9
6.0 m		2.85	2.8	3.1	3.05	2.75
7.0 m		2.1	2.05	2.3	2.45	2.35
8.0 m		1.7	1.45	1.75	1.85	1.95
9.0 m		(7.7m)	1.05	1.3	1.45	1.55
10.0 m			0.75	1.0	1.15	1.25
11.0 m			0.55	0.75	0.9	1.0
12.0 m			0.45	0.55	0.7	0.8
13.0 m			(11.4m)	0.4	0.5	0.65
14.0 m				0.3	0.4	0.5
15.0 m				0.2	0.3	0.35
16.0 m					0.2	0.25
17.0 m						0.2
D (°)	0				21	36

A : Boom length

B : Load radius

D : Minimum boom angle (°) for indicated length (no load)

RATED LIFTING CAPACITIES

I S O 4 3 0 5

ON OUTRIGGERS

Unit : x1,000kg

Outriggers extended to middle (2.5 m) - Over side -						
A B	5.3 m	9.0 m	12.7 m	16.4 m	20.1 m	23.8 m
1.0 m	12.0	6.0				
1.5 m	12.0	6.0	6.0			
2.0 m	12.0	6.0	6.0	5.0		
2.5 m	8.0	6.0	6.0	5.0	4.7	
3.0 m	5.7	5.6	5.6	5.0	4.7	
3.5 m	4.25	4.4	4.4	4.5	4.5	3.2
4.0 m	3.45	3.4	3.35	3.6	3.7	3.2
4.5 m		2.65	2.65	2.9	3.1	3.0
5.0 m		2.15	2.15	2.35	2.55	2.7
5.5 m		1.75	1.7	1.95	2.15	2.25
6.0 m		1.4	1.35	1.65	1.8	1.95
7.0 m		0.9	0.9	1.1	1.25	1.4
8.0 m		0.65	0.55	0.75	0.9	1.05
9.0 m		(7.7m)	0.3	0.5	0.65	0.8
10.0 m				0.3	0.45	0.55
11.0 m					0.3	0.35
12.0 m						0.25
D (°)	0		19	33	44	50

A : Boom length B : Load radius

D : Minimum boom angle (°) for indicated length (no load)

ON OUTRIGGERS

Unit : x1,000kg

Outriggers extended to minimum (1.64 m) - Over side -						
A B	5.3 m	9.0 m	12.7 m	16.4 m	20.1 m	23.8 m
1.0 m	8.0	6.0				
1.5 m	7.0	6.0	6.0			
2.0 m	5.5	5.4	5.5	5.0		
2.5 m	3.7	3.8	3.55	3.2	3.2	
3.0 m	2.7	2.85	2.65	2.6	2.6	
3.5 m	2.1	2.0	2.0	2.05	2.1	2.1
4.0 m	1.6	1.55	1.5	1.6	1.7	1.75
4.5 m		1.15	1.1	1.25	1.4	1.45
5.0 m		0.85	0.85	1.0	1.15	1.25
5.5 m		0.6	0.65	0.8	0.95	1.05
6.0 m		0.45	0.45	0.6	0.75	0.85
7.0 m				0.35	0.45	0.55
8.0 m						0.35
D (°)	0	18	50	56	60	63

A : Boom length B : Load radius

D : Minimum boom angle (°) for indicated length (no load)

RATED LIFTING CAPACITIES

ISO 4305

ON OUTRIGGERS

Outriggers fully extended (4.7m) - 360° rotation -																
C	23.8m Boom + 3.6m Jib								23.8m Boom + 5.5m Jib							
	Offset								Offset							
	5°		25°		45°		60°		5°		25°		45°		60°	
	R	W	R	W	R	W	R	W	R	W	R	W	R	W	R	W
82	4.1	1.6	5.3	1.2	6.3	1.0	6.6	0.65	4.5	1.0	6.3	0.7	7.8	0.65	8.4	0.4
80	5.1	1.6	6.2	1.2	7.2	1.0	7.5	0.65	5.6	1.0	7.3	0.7	8.8	0.65	9.3	0.4
75	7.6	1.55	8.7	1.2	9.4	0.93	9.6	0.65	8.3	1.0	9.9	0.7	11.1	0.63	11.5	0.4
70	9.9	1.25	11.0	1.0	11.6	0.85	11.7	0.65	10.8	1.0	12.3	0.65	13.3	0.58	13.5	0.4
65	12.1	1.05	13.1	0.9	13.6	0.77	13.6	0.65	13.1	0.81	14.6	0.61	15.4	0.52	15.5	0.4
60	14.2	0.9	15.1	0.8	15.5	0.7	15.5	0.65	15.3	0.69	16.7	0.55	17.3	0.48	17.3	0.4
55	16.1	0.69	16.9	0.65	17.3	0.64			17.4	0.58	18.6	0.5	19.1	0.45		
50	17.8	0.5	18.5	0.47	18.8	0.47			19.2	0.45	20.3	0.42	20.7	0.41		
45	19.5	0.36	20.0	0.34	20.2	0.34			21.0	0.32	21.9	0.3	22.1	0.29		
40	20.9	0.26	21.4	0.24					22.5	0.22	23.2	0.21				
35	22.2	0.17	22.6	0.17												

C : Boom angle (°) R : Load radius (m) W : Rated lifting capacity (x 1,000kg)

ON OUTRIGGERS

Outriggers extended to middle (4.3m) - Over side -																
C	23.8m Boom + 3.6m Jib								23.8m Boom + 5.5m Jib							
	Offset								Offset							
	5°		25°		45°		60°		5°		25°		45°		60°	
	R	W	R	W	R	W	R	W	R	W	R	W	R	W	R	W
82	4.1	1.6	5.3	1.2	6.3	1.0	6.6	0.65	4.5	1.0	6.3	0.7	7.8	0.65	8.4	0.4
80	5.1	1.6	6.2	1.2	7.2	1.0	7.5	0.65	5.6	1.0	7.3	0.7	8.8	0.65	9.3	0.4
75	7.6	1.55	8.7	1.2	9.4	0.93	9.6	0.65	8.3	1.0	9.9	0.7	11.1	0.63	11.5	0.4
70	9.9	1.25	11.0	1.0	11.6	0.85	11.7	0.65	10.8	1.0	12.3	0.65	13.3	0.58	13.5	0.4
65	12.1	1.05	13.1	0.9	13.6	0.77	13.6	0.65	13.1	0.81	14.6	0.61	15.4	0.52	15.5	0.4
60	14.1	0.8	15.0	0.74	15.5	0.7	15.5	0.65	15.3	0.69	16.7	0.55	17.3	0.48	17.3	0.4
55	16.1	0.55	16.8	0.52	17.2	0.5			17.4	0.5	18.6	0.45	19.1	0.45		
50	17.8	0.37	18.5	0.35	18.8	0.34			19.2	0.34	20.2	0.31	20.6	0.31		
45	19.4	0.24	20.0	0.23	20.2	0.22			20.9	0.22	21.7	0.2	22.0	0.2		

C : Boom angle (°) R : Load radius (m) W : Rated lifting capacity (x 1,000kg)

RATED LIFTING CAPACITIES

ISO 4305

ON OUTRIGGERS

Outriggers extended to middle (3.5m) - Over side -																	
C	23.8m Boom + 3.6m Jib								23.8m Boom + 5.5m Jib								
	Offset								Offset								
	5°		25°		45°		60°		5°		25°		45°		60°		
	R	W	R	W	R	W	R	W	R	W	R	W	R	W	R	W	
82	4.1	1.6	5.3	1.2	6.3	1.0	6.6	0.65	4.5	1.0	6.3	0.7	7.8	0.65	8.4	0.4	
80	5.1	1.6	6.2	1.2	7.2	1.0	7.5	0.65	5.6	1.0	7.3	0.7	8.8	0.65	9.3	0.4	
75	7.6	1.55	8.7	1.2	9.4	0.93	9.6	0.65	8.3	1.0	9.9	0.7	11.1	0.63	11.5	0.4	
70	9.9	1.25	11.0	1.0	11.6	0.85	11.7	0.65	10.8	1.0	12.3	0.65	13.3	0.58	13.5	0.4	
65	12.0	0.8	13.0	0.7	13.6	0.7	13.6	0.65	13.1	0.66	14.5	0.52	15.4	0.45	15.5	0.4	
60	14.0	0.5	14.9	0.46	15.4	0.45	15.5	0.42	15.1	0.45	16.4	0.35	17.2	0.33	17.3	0.3	
55	15.8	0.28	16.7	0.27	17.1	0.23			17.1	0.23	18.3	0.2	18.9	0.19			

C : Boom angle (°) R : Load radius (m) W : Rated lifting capacity (x 1,000kg)

ON OUTRIGGERS

Outriggers extended to middle (2.5m) - Over side -																	
C	23.8m Boom + 3.6m Jib								23.8m Boom + 5.5m Jib								
	Offset								Offset								
	5°		25°		45°		60°		5°		25°		45°		60°		
	R	W	R	W	R	W	R	W	R	W	R	W	R	W	R	W	
82	4.1	1.60	5.3	1.20	6.3	1.00	6.6	0.65	4.5	1.00	6.3	0.70	7.8	0.65	8.4	0.40	
75	7.5	1.10	8.5	0.90	9.4	0.80	9.6	0.65	8.3	1.00	9.8	0.65	11.1	0.58	11.5	0.40	
70	9.7	0.57	10.7	0.50	11.4	0.45	11.6	0.40	10.4	0.50	12.0	0.40	13.2	0.35	13.5	0.30	
65	11.8	0.25	12.7	0.22	13.4	0.20	13.4	0.15	12.6	0.20							

C : Boom angle (°) R : Load radius (m) W : Rated lifting capacity (x 1,000kg)

RATED LIFTING CAPACITIES

ISO 4305

ON OUTRIGGERS

		Outriggers fully extended (4.7m)										- 360° rotation -					
C	20.1m Boom + 3.6m Jib								20.1m Boom + 5.5m Jib								
	Offset								Offset								
	5°		25°		45°		60°		5°		25°		45°		60°		
	R	W	R	W	R	W	R	W	R	W	R	W	R	W	R	W	
82	3.5	1.60	4.7	1.40	5.6	1.00	6.0	0.65	3.9	1.00	5.8	1.00	7.1	0.65	7.8	0.40	
80	4.3	1.60	5.5	1.40	6.4	1.00	6.7	0.65	4.8	1.00	6.7	1.00	8.0	0.65	8.6	0.40	
75	6.4	1.60	7.5	1.30	8.3	0.95	8.5	0.65	7.1	1.00	8.8	0.88	9.9	0.63	10.4	0.40	
70	8.4	1.45	9.4	1.15	10.1	0.90	10.2	0.65	9.2	1.00	10.8	0.79	11.8	0.58	12.1	0.40	
65	10.3	1.25	11.2	1.00	11.8	0.86	11.8	0.65	11.3	0.96	12.8	0.72	13.6	0.55	13.7	0.40	
60	12.1	1.10	12.9	0.90	13.4	0.80	13.4	0.65	13.2	0.84	14.5	0.67	15.2	0.52	15.3	0.40	
55	13.7	0.90	14.5	0.75	14.9	0.70			15.0	0.73	16.2	0.60	16.8	0.49			
50	15.2	0.66	15.9	0.60	16.2	0.54			16.6	0.56	17.7	0.48	18.1	0.45			
45	16.7	0.48	17.2	0.44	17.5	0.41			18.1	0.40	19.1	0.36	19.3	0.32			
40	17.9	0.34	18.5	0.31					19.5	0.27	20.3	0.24					
35	19.1	0.22	19.5	0.21					20.7	0.17	21.4	0.16					

C : Boom angle (°) R : Load radius (m) W : Rated lifting capacity (x 1,000kg)

ON OUTRIGGERS

		Outriggers extended to middle (4.3m)										- Over side -					
C	20.1m Boom + 3.6m Jib								20.1m Boom + 5.5m Jib								
	Offset								Offset								
	5°		25°		45°		60°		5°		25°		45°		60°		
	R	W	R	W	R	W	R	W	R	W	R	W	R	W	R	W	
82	3.5	1.60	4.7	1.40	5.6	1.00	6.0	0.65	3.9	1.00	5.8	1.00	7.1	0.65	7.8	0.40	
80	4.3	1.60	5.5	1.40	6.4	1.00	6.7	0.65	4.8	1.00	6.7	1.00	8.0	0.65	8.6	0.40	
75	6.4	1.60	7.5	1.30	8.3	0.95	8.5	0.65	7.1	1.00	8.8	0.88	9.9	0.63	10.4	0.40	
70	8.4	1.45	9.4	1.15	10.1	0.90	10.2	0.65	9.2	1.00	10.8	0.79	11.8	0.58	12.1	0.40	
65	10.3	1.25	11.2	1.00	11.8	0.86	11.8	0.65	11.3	0.96	12.8	0.72	13.6	0.55	13.7	0.40	
60	12.0	1.00	12.9	0.90	13.4	0.80	13.4	0.65	13.2	0.84	14.5	0.67	15.2	0.52	15.3	0.40	
55	13.7	0.72	14.4	0.66	14.9	0.62			15.0	0.63	16.2	0.55	16.8	0.49			
50	15.2	0.49	15.9	0.44	16.2	0.43			16.6	0.41	17.7	0.37	18.1	0.34			
45	16.6	0.31	17.2	0.28	17.4	0.28			18.1	0.26	19.0	0.22	19.2	0.21			
40	17.8	0.18	18.4	0.17					19.5	0.15							

C : Boom angle (°) R : Load radius (m) W : Rated lifting capacity (x 1,000kg)

RATED LIFTING CAPACITIES

ISO 4305

ON OUTRIGGERS

Outriggers extended to middle (3.5m) - Over side -																
C	20.1m Boom + 3.6m Jib								20.1m Boom + 5.5m Jib							
	Offset								Offset							
	5°		25°		45°		60°		5°		25°		45°		60°	
	R	W	R	W	R	W	R	W	R	W	R	W	R	W	R	W
82	3.5	1.60	4.7	1.40	5.6	1.00	6.0	0.65	3.9	1.00	5.8	1.00	7.1	0.65	7.8	0.40
80	4.3	1.60	5.5	1.40	6.4	1.00	6.7	0.65	4.8	1.00	6.7	1.00	8.0	0.65	8.6	0.40
75	6.4	1.60	7.5	1.30	8.3	0.95	8.5	0.65	7.1	1.00	8.8	0.88	9.9	0.63	10.4	0.40
70	8.4	1.45	9.4	1.15	10.1	0.90	10.2	0.65	9.2	1.00	10.8	0.79	11.8	0.58	12.1	0.40
65	10.2	0.93	11.1	0.82	11.8	0.78	11.8	0.65	11.2	0.83	12.8	0.72	13.6	0.55	13.7	0.40
60	11.9	0.59	12.8	0.51	13.4	0.47	13.4	0.47	13.0	0.50	14.4	0.42	15.2	0.36	15.3	0.40
55	13.6	0.33	14.4	0.28	14.8	0.26			14.8	0.27	16.1	0.22	16.7	0.20		
50	15.1	0.15														

C : Boom angle (°) R : Load radius (m) W : Rated lifting capacity (x 1,000kg)

ON OUTRIGGERS

Outriggers extended to middle (2.5m) - Over side -																
C	20.1m Boom + 3.6m Jib								20.1m Boom + 5.5m Jib							
	Offset								Offset							
	5°		25°		45°		60°		5°		25°		45°		60°	
	R	W	R	W	R	W	R	W	R	W	R	W	R	W	R	W
82	3.5	1.60	4.7	1.40	5.6	1.00	6.0	0.65	3.9	1.00	5.8	1.00	7.1	0.65	7.8	0.40
75	6.3	1.15	7.5	0.95	8.3	0.80	8.5	0.65	7.1	1.00	8.8	0.80	9.9	0.63	10.4	0.40
70	8.2	0.61	9.3	0.53	10.0	0.48	10.2	0.48	9.0	0.52	10.7	0.44	11.7	0.38	12.1	0.37
65	10.1	0.28	11.1	0.24	11.7	0.22	11.8	0.22	11.0	0.22						

C : Boom angle (°) R : Load radius (m) W : Rated lifting capacity (x 1,000kg)

NOTES FOR "ON OUTRIGGERS" TABLES

1. Rated lifting capacities based on crane stability are according to ISO 4305.
2. Rated lifting capacities shown in the table are based on condition that crane is set on firm level surface. Those above bold lines are based on crane strength and those below, on its stability.
3. The mass of the hook (90 kg for 12,000 kg capacity, 25 kg for 1,800 kg capacity), slings and all similarly used load handling devices must be considered as part of the load and must be deducted from the lifting capacities.
4. Jib operation should be based on boom angle irrespective of boom length.
The working radius shown above is reference value with jib mounted to 23.8m boom and 20.1m boom.
5. For rated lifting capacity of single top, reduce the 65 kg from the relevant boom rated lifting capacity.
Rated lifting capacity of single top should not exceed 1,800 kg.
6. High-speed down hoisting should be performed without any load on the hook.
Be sure to operate the levers slowly.
7. Standard number of parts of line for each boom length is as shown below.

Load per line should not surpass 1,800 kg for main winch and auxiliary winch.

Boom length (m)	5.3	9.0	12.7	16.4	20.1	23.8	JIB/Single top
No. of parts of line	8	4	4	4	4	4	1

The lifting capacity data stored in the AUTOMATIC LIMITER(AML-C) is based on the standard number of parts of line listed in the chart.

Maximum lifting capacity is restricted by the number of parts of line of AUTOMATIC MOMENT LIMITER(AML-C).

8. The over-side rated lifting capacity depends on outrigger extension. Rated lifting capacity of over-front and over-rear assume fully extended outrigger position. Working area for each outrigger position are given separately and must be followed accordingly during operation.

Outriggers position	Extended to middle (4.3 m)	Extended to middle (3.5 m)	Extended to middle (2.5 m)	Extended to minimum (1.64 m)
Angle a°	45	35	25	15

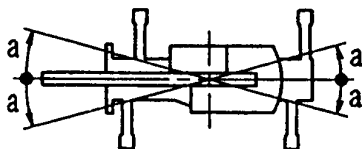

RATED LIFTING CAPACITIES

ISO 4305

ON TIRES

Unit : x1,000kg

Load radius	Stationary					
	5.3 m Boom		9.0 m Boom		12.7 m Boom	
	Over front	360°	Over front	360°	Over front	360°
1.0 m	3.6	2.8	3.6	2.8		
1.5 m	3.6	2.8	3.6	2.8	3.6	2.8
2.0 m	3.4	2.8	3.4	2.8	3.4	2.8
2.5 m	3.1	2.15	3.1	2.1	3.1	2.05
3.0 m	2.65	1.6	2.6	1.55	2.55	1.5
3.5 m	2.3	1.25	2.2	1.2	2.1	1.1
4.0 m	2.0	0.9	1.9	0.8	1.7	0.7
4.5 m			1.6	0.5	1.4	0.4
5.0 m			1.3		1.1	
5.5 m			1.1		0.95	
6.0 m			0.9		0.8	
7.0 m			0.5		0.5	

ON TIRES

Unit : x1,000kg

Load radius	Creep					
	5.3 m Boom		9.0 m Boom		12.7 m Boom	
	Over front	360°	Over front	360°	Over front	360°
1.0 m	3.2	2.0	3.2	2.0		
1.5 m	3.2	2.0	3.2	2.0	3.2	2.0
2.0 m	3.0	2.0	3.0	2.0	3.0	2.0
2.5 m	2.8	1.55	2.75	1.5	2.65	1.45
3.0 m	2.4	1.1	2.3	1.05	2.2	1.0
3.5 m	2.0	0.85	1.9	0.75	1.8	0.65
4.0 m	1.7	0.6	1.65	0.5	1.5	0.4
4.5 m			1.4	0.3	1.25	
5.0 m			1.15		1.0	
5.5 m			0.95		0.85	
6.0 m			0.8		0.7	
7.0 m			0.45		0.45	

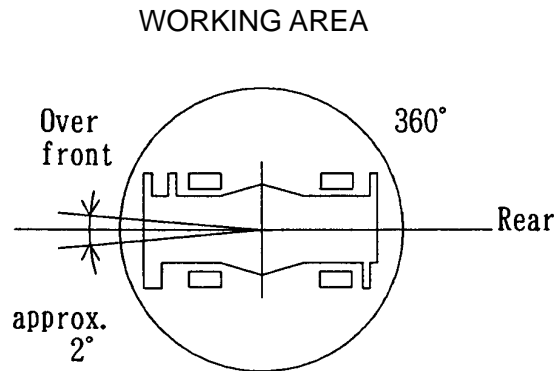

Without outriggers "Over front" operation should be performed within 2 degrees in front of chassis.

NOTES FOR "ON TIRES" TABLES

1. Rated lifting capacities based on crane stability are according to ISO 4305.
2. Rated lifting capacities shown in the table are based on condition that crane is set on firm level surface, with suspension lock applied. Those above bold lines are based on tire capacity and those below, on crane stability. They are based on actual working radii increased by tire deformation and boom deflection.
3. The mass of the hook (90 kg for 12,000 kg capacity, 25 kg for 1,800 kg capacity), slings and all similarly used load handling devices must be considered as part of the load and must be deducted from the lifting capacities.
4. For rated lifting capacity of single top, reduce the 65 kg from the relevant boom rated lifting capacity.
Rated lifting capacity of single top should not exceed 1,800 kg.
5. High-speed down hoisting and on tires lifting with "jib" is not permitted.
Maximum permissible boom length is 12.7 m.
6. CREEP is motion for crane not to travel more than 60 m in any 30 min. period and to travel at the speed of less than 1.6 km/h.
7. During "CREEP" duties travel slowly and keep the lifting load as close to the ground as possible, and especially avoid any abrupt steering, accelerating or braking.
8. Do not operate the crane while carrying the load.
9. Tires should be inflated to their correct air pressure of 900 kPa {9.0 kgf/cm²}.
10. For CREEP operation, set Drive select switch to "4-WHEEL(Lo)" and set gear shift lever to "1".
11. Standard number of parts of line for each boom length is as shown below.
Load per line should not surpass 1,800 kg for main winch and auxiliary winch.

Boom length (m)	5.3	9.0	12.7	Single top
No. of parts of line	4	4	4	1

WORKING RANGE

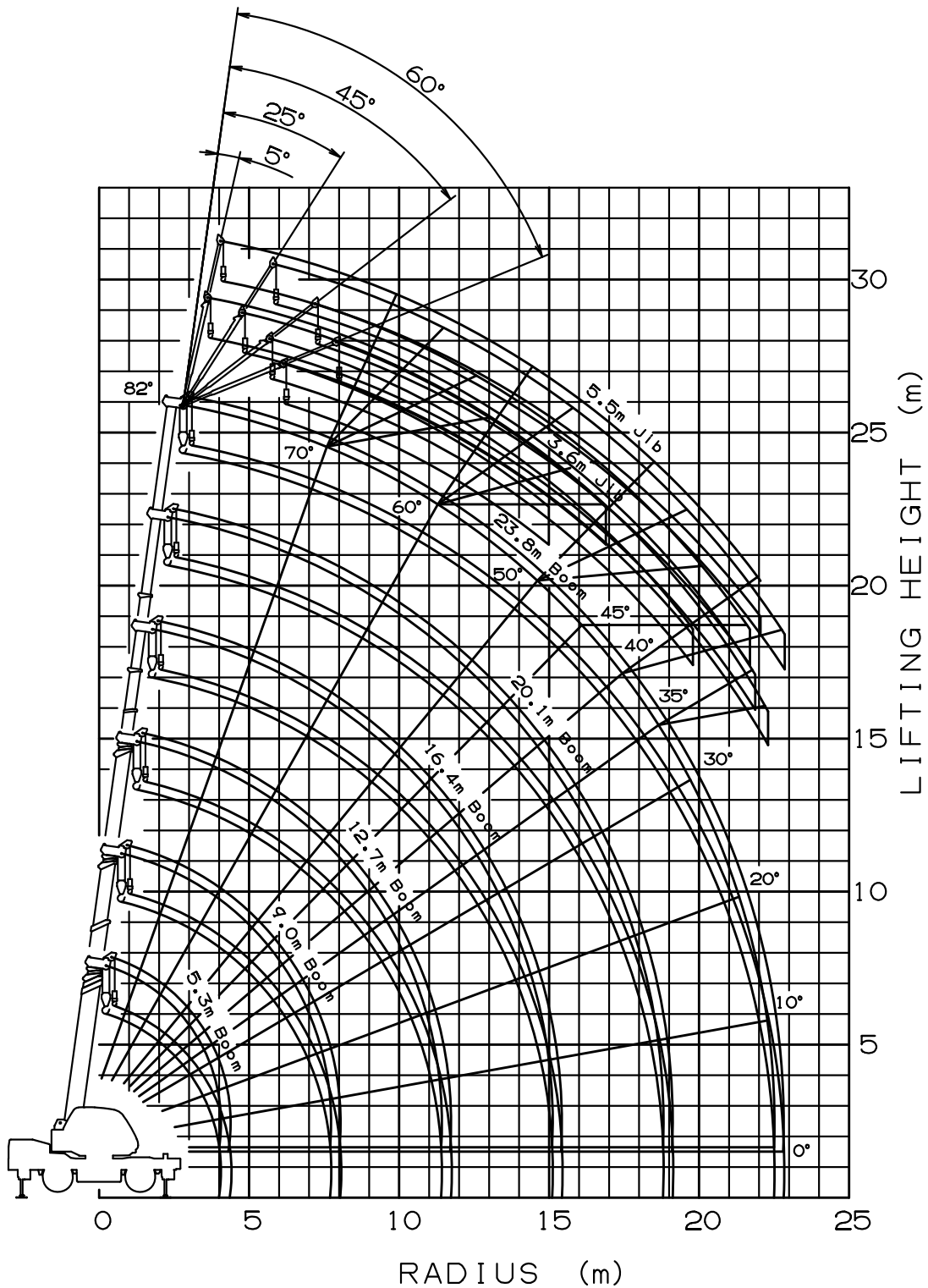

- NOTE: 1. The above lifting heights and boom angles are based on a straight (unladen) boom, and allowance should be made for boom deflection obtained under laden conditions.
2. The above working range is shown on condition with outriggers fully extended. (360°)

EXTERNAL VIEWS

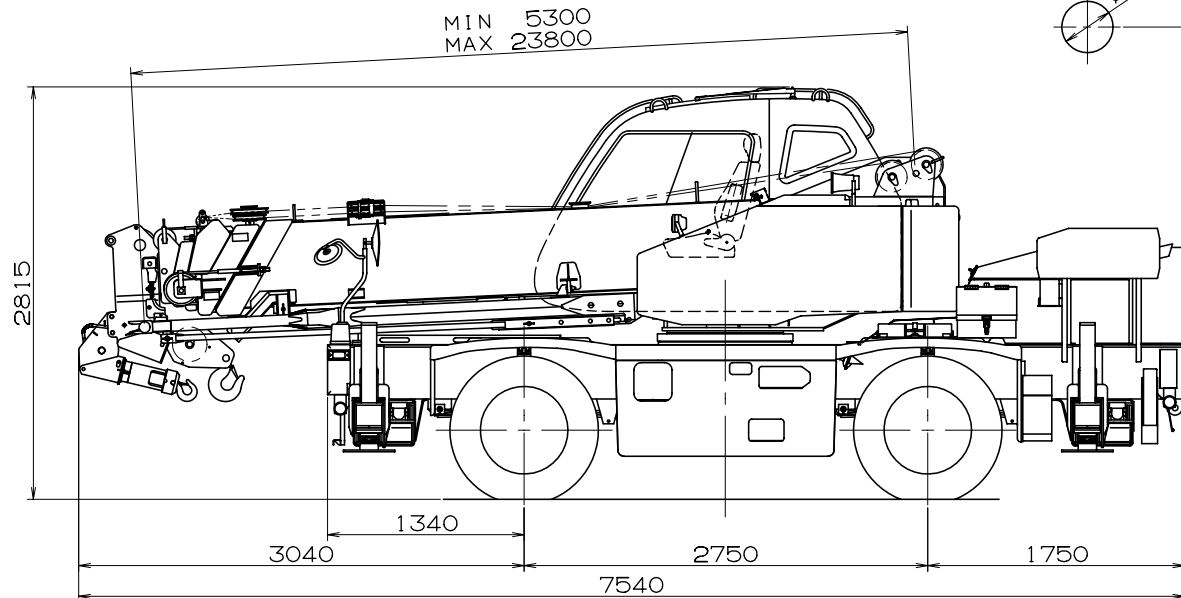
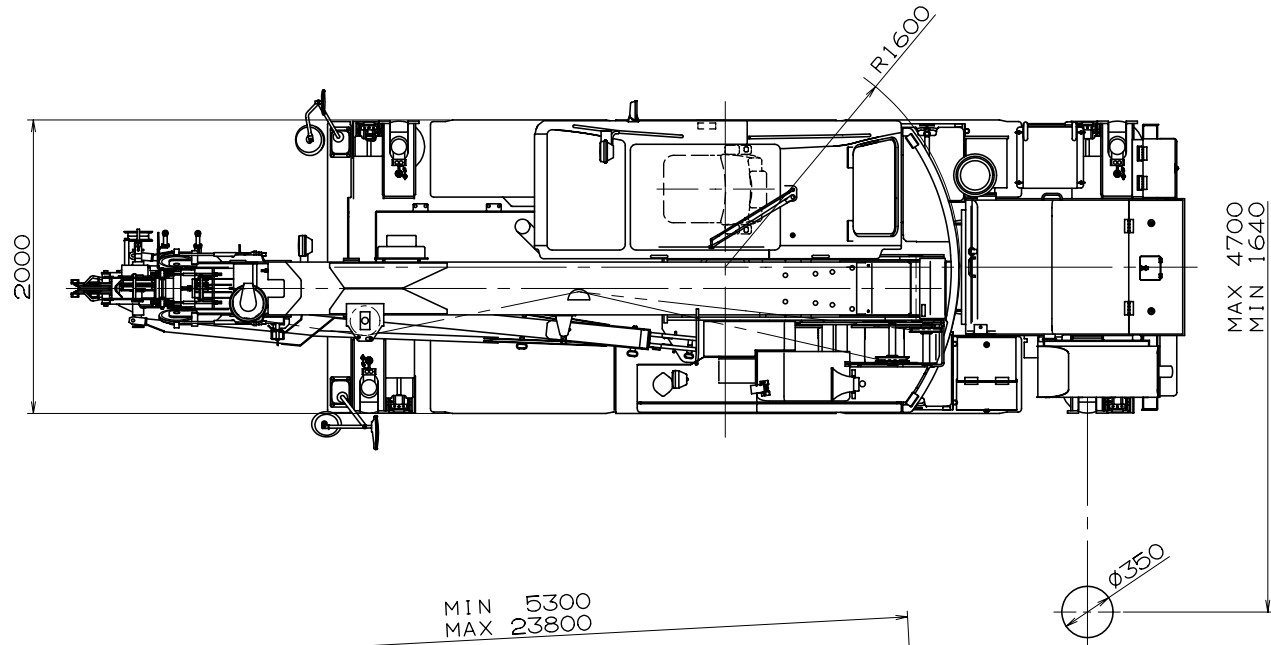
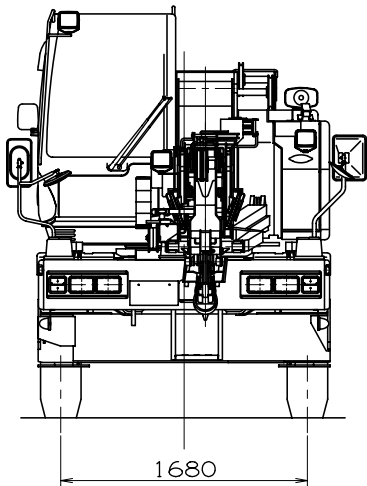
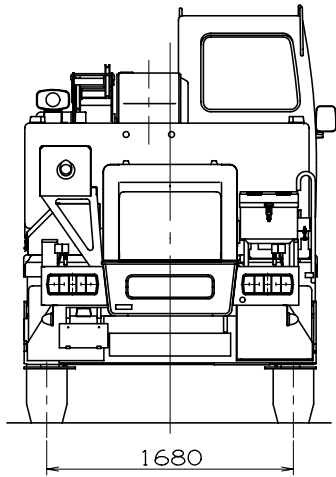

NOTE : In this external views, a few equipment are included.