

TADANO CARGO CRANE

MODEL : TM-ZR505G

CRANE SPECIFICATIONS

<u>CRANE CAPACITY</u>	4,040 kg at 2.85 m (5-part lines)
<u>BOOM</u>	5-sectioned, fully powered partly synchronized telescoping boom of pentagonal box construction Retracted length — 3.77 m Extended length — 13.34 m Extending speed — 9.57 m / 25 s Elevation ————— Elevated by a double-acting hydraulic cylinder Elevating speed — 1° to 78° / 12 s Boom point ————— 3 sheaves
<u>WINCH</u>	Hydraulic motor driven Spur gear speed reduction, provided with mechanical brake and cable follower Single line pull — 7.92 kN{808 kgf} Single line speed — 76 m/min (at 4th layer) Wire rope diameter × length — 8 mm × 97 m breaking strength — 43.1 kN{4.39 tf} construction — 7 × 7 + 6 × WS(26) Hook block ————— 2 sheaves

<u>SWING</u>	Hydraulic motor driven Worm gear speed reduction Continuous 360° full circle swing on ball bearing slew ring Automatic swing lock Swing speed ————— 2.5 min ⁻¹ {rpm}
<u>OUTRIGGERS</u>	Manually extended sliders and hydraulically extended jacks Integral with crane frame Power up and down Extended width ——— Min. 2,200 mm Mid. 3,000 mm Max. 3,800 mm
<u>HYDRAULICS</u>	Hydraulic pump ————— Single gear pump Hydraulic motors ————— Axial piston type for winch Axial piston type for swing Control valves ————— Multiple control valves with integral safety valve
<u>SAFETY DEVICES</u>	Load meter Load indicator Over-winding alarm P.T.O. indicator lamp Hook safety latch Level gauge Hydraulic safety valves, check valves and holding valves
<u>CRANE MASS</u>	Approx. 1,980 kg (includes standardized mounting parts)

NOTE : Operating speeds of the crane are guaranteed under the condition that the pump delivery is 60 L/min.

RATED LIFTING CAPACITIES IN KILOGRAMS

A B	3.77 m 6.21 m	A B	8.59 m	A B	10.97 m	A B	13.34 m
2.85m and below	4,040	3.8 m and below	3,030	4.5 m and below	2,030	5.0 m and below	1,330
3.4 m	3,380	4.5 m	2,430	5.0 m	1,830	6.0 m	1,100
3.8 m	3,030	5.0 m	2,130	6.0 m	1,480	7.0 m	950
4.5 m	2,430	5.5 m	1,880	7.0 m	1,230	8.0 m	830
5.0 m	2,130	6.0 m	1,650	8.0 m	1,030	9.0 m	730
5.5 m	1,880	6.5 m	1,480	9.0 m	880	10.0 m	650
5.99m	1,650	7.0 m	1,350	10.0 m	780	11.0 m	600
		7.5 m	1,230	10.75m	730	12.0 m	550
		8.37m	1,080			13.12m	500

A : Boom Length

B : Load radius

NOTES :

1. The mass of the hook (45 kg), slings and all similarly used load handling devices must be added to the mass of the load.
2. The above numerical values of rated lifting capacities are based on crane strength only.

The rated lifting capacities based on stability may lower than those in the above table depending on the loading conditions and the types of the chassis.

WORKING RANGE

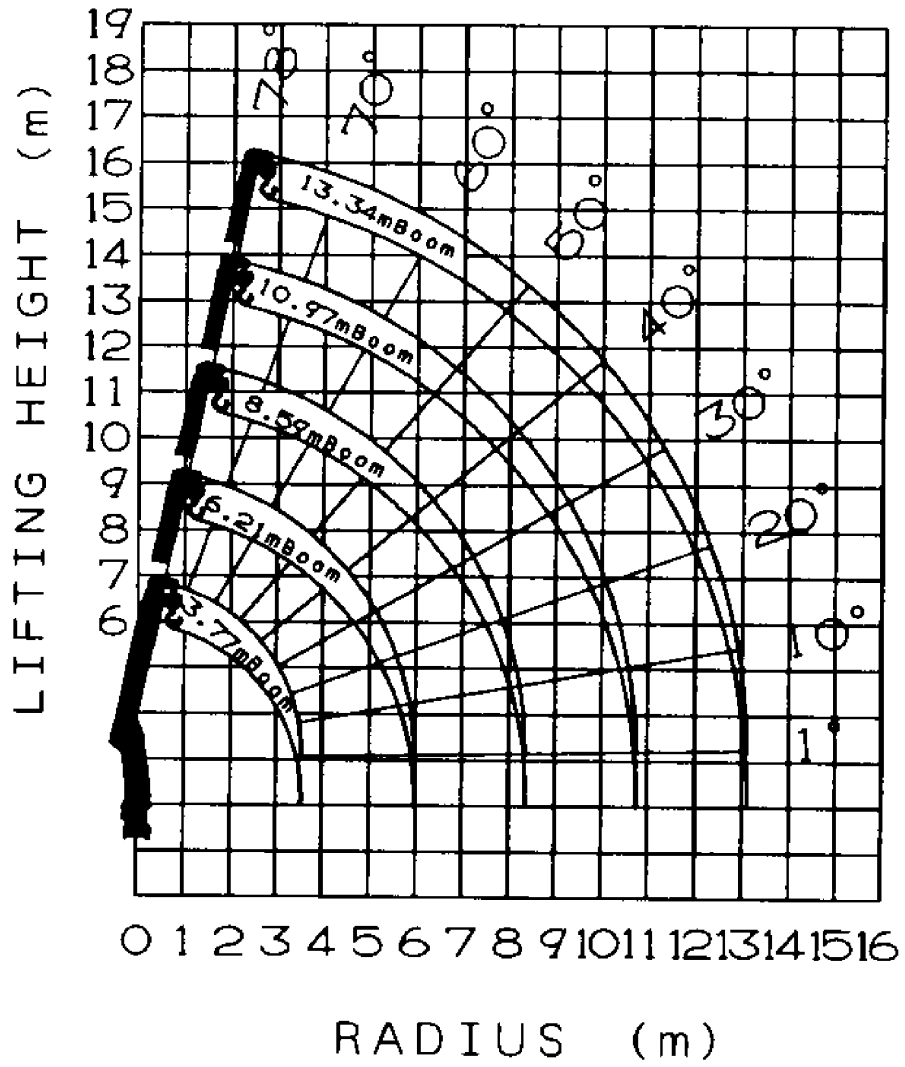

NOTE:

The above lifting heights and boom angles are based on a straight (unladen) boom, and allowance should be made for boom deflection obtained under laden conditions.

DIMENSIONS

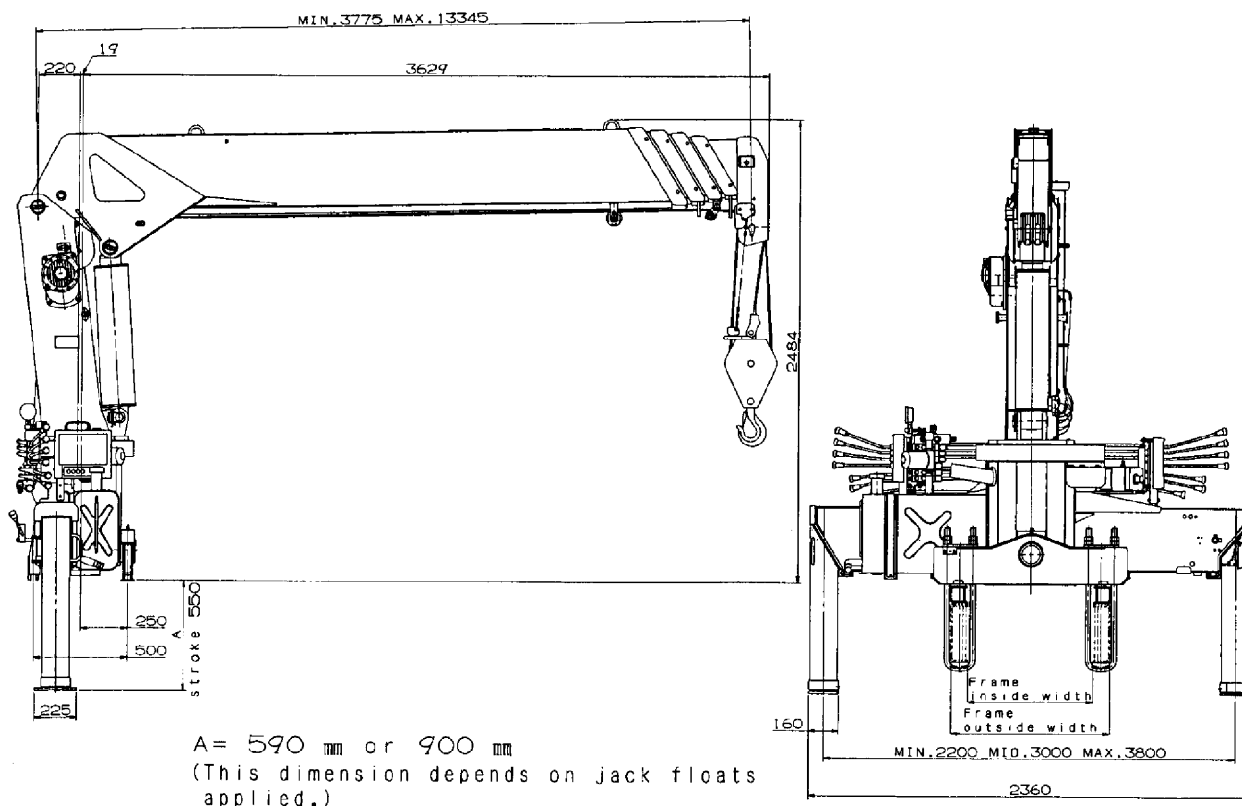

GENERAL DATA FOR SUITABLE TRUCKS

- Gross vehicle mass (including crane mass) —
12,000 to 25,000 kg
- P.T.O. torque ————— 157 N·m {16 kgf·m} min.
- P.T.O. revolution ————— Approx. 270 to 2,800 min⁻¹ {rpm}
- Width for crane mounting — Approx. 750 mm min.
- Frame ————— Weight distribution and frame strength
should be calculated for each truck
- Frame width range (inside to outside) —
Approx. 610 to 960 mm
- Frame height (ground to frame top) —
Approx. 1,235 mm max.
(Height of crane mounting base can be
changed by combination of jack floats
and crane bases)